



"WE PRODUCE, THE WORLD USES..."

"ÜRETİYORUZ, DÜNYA KULLANIYOR..."



M: (+90) 532 791 84 24  
P: (+90) 212 655 00 72



SLIDE AJANS - 2024/08 © 0312 612 0948

**Factory 1**  
Karaağaç Mah. Batu Sok. No:9/1  
Hadımköy - Büyükçekmece - İSTANBUL

**Factory 2**  
Avrupa San. Sit. B Blok No:6  
Kapaklı - Çerkezköy - TEKİRDAĞ

**Factory 3**  
Canbazlarköyü Mah. Kanal Sok.  
Kapı: 10 İç Kapı No:1 Gürsu - BURSA

info@erkur.com / www.erkur.com

## ZİNCİR VE KONVEYÖR SİSTEMLERİ

CHAIN and CONVEYOR SYSTEMS

"WE PRODUCE, THE WORLD USES..."

"ÜRETİYORUZ, DÜNYA KULLANIYOR..."

**Türkiye**  
Gücünü ve  
Potansiyelini Keşfet



# HAKKIMIZDA ABOUT US

İstanbul'un Hadımköy semtinde konumlanan Erkur Makine tüm yatırımlarını kendi öz kaynaklarıyla yapabilmesi neticesinde kurulduğu günden bu güne geçen sürede, sektörünün söz sahibi firmalarından biri haline gelmiştir. Üretimini, sürekli ilerleyen ve gelişen teknolojiyi yakından takip ederek geliştirmekte, güncel bir üretim teknolojisini izlemektedir. Kardan , webb , power and free, özel zincir, paletli, rulolu , zincirli, skid konveyörleri, rgv taşıma arabaları, özel proses makineleri, robotik otomasyon alanlarında hizmet vermektedir. Ürünlerimiz; işleme hatları, lojistik hatlar, montaj ve boyama hatları ve üretim ile ilgili her prosese yöneliktir.

Kaliteyle birlikte verimlilik de firmamız için büyük önem arz etmektedir. Erkur makine, ürünlerini istenilen kalitede ve zamanında teslim ederek, müşteri memnuniyetini en üst düzeyde tutmaya gayret etmektedir.

Erkur Makine is a strong company capable of making all needed investments with its own resources.

The company improves and updates its manufacturing capabilities by closely following technological developments.

It provides services in the fields of cardan, webb, power and free, special chain, pallet, roller, chain, skid conveyors, rgv transport cars, special process machines and robotic automation. Our products; It is aimed at processing lines, logistics lines, assembly and painting lines and every process related to production.

In addition, manufacturing efficiency is as important as quality from the point of view of Erkur Makine.

## NELER ÜRETİYORUZ ? WHAT DO WE PRODUCE ?

- Askılı konveyör sistemleri
- Talaş konveyör sistemleri
- Bant konveyör sistemleri
- Silo konveyör sistemleri
- Taşıyıcı ve özel konveyör zincirleri
- Verilen teknik çizime ya da ihtiyaçlara yönelik tarafımızdan size özel tasarlanan standart olmayan zincirler
- Overhead Conveyor Systems
- Chip Conveyor Systems
- Belt Conveyor Systems
- Silo Conveyor Systems
- Carrier and Conveyor Chains
- Non-standard chains, which are designed to your specific needs, according to the delivered technical drawings or your requirements.

## ASKILI KONVEYÖR SİSTEMLERİ OVERHEAD CONVEYOR SYSTEMS

Askılı konveyör sistemleri, yükün havadan taşınmasında kullanılan sistemlerdir. 20 tona kadar yük taşıyabilmektedir.

1. Webb tipi askılı konveyörler, 3", 4", 6" trolley ve zincirleri ile birlikte
2. Hafif, orta ve ağır tip kardan tipi konveyörler
3. Hafif, orta ve ağır tip fivet tipi askılı konveyörler.
4. Power and free konveyörü

Hanger conveyor systems are systems used to transport cargo by air. It can carry up to 20 tons of load.

1. Webb type overhead conveyors with, 3",4",6" trolleys and chains
2. Light, middle and heavy type, universal conveyors
3. Light, middle and heavy type, fivet type overhead conveyors
4. Power and free conveyor

# İÇİNDEKİLER INDEX

info@erkur.com / www.erkur.com

**02**

### KULLANIM ALANLARI

Areas of Usega

**03**

### TAŞIYICI VE ÖZEL KONVEYÖR ZİNCİRLERİ

Carrier And Special  
Conveyor Chains

**04**

### POWER AND FREE KONVEYÖR RAY VE BARALARI

Power and Free Conveyor  
Rails and Bara

**05/06**

### POWER AND FREE KONVEYÖRLER

Power and Free  
Conveyors

**07**

### KARDAN KONVEYÖR RAYLARI ve ZİNCİRLERİ

Cardanic Conveyor Rails  
and Chains

**08**

### KARDAN KONVEYÖRLER VE DİĞER EKİPMANLAR

Cardan Conveyors  
And Other Equipment

**09**

### KARDAN KONVEYÖRLER

Cardanic Conveyors

**10**

### FİVET TİPİ KONVEYÖRLER VE DİĞER EKİPMANLAR

Fivet Type Conveyors  
And Other Equipment

**11**

### WEBB TİPİ KONVEYÖR ZİNCİR VE TROLLEYLERİ

Webb Type Conveyor  
Chains and Trolleys

**12**

### WEBB TİPİ KONVEYÖRLER VE DİĞER EKİPMANLAR

Webb Type Conveyors  
And Other Equipment

**13**

### WEBB TİPİ KONVEYÖRLER

Webb Type Conveyors

**14**

### KONVEYÖR PROJELERİ

Conveyor Projects

**15/16**

### KONVEYÖR VE LİFT ÖRNEKLERİ

Conveyor and Lift  
Examples

**17/20**

### ÖZEL KONVEYÖR ZİNCİRLERİ

Special Conveyor Chains

**21/25**

### REFERANSLARIMIZ

Our References

KNOW ERKUR MACHINE CLOSER

ERKUR MAKİNE'Yİ YAKINDAN TANIYIN

# KULLANIM ALANLARI

## Areas of Use



### KONVEYÖR SİSTEMLERİ

Konveyör sistemleri yüzey işlem tesisleri, nakliye, sevkiyat ve stok hatlarıyla beraber çok çeşitli endüstriyel uygulamalarda kullanılmaktadır.

1. Toz ve yağ boya sistemlerinde
2. Otomotiv yan sanayi fabrikalarında
3. Beyaz eşya fabrikalarında
4. Emaye eşya fabrikalarında
5. Alüminyum eşya fabrikalarında
6. Kazan, tank ve tüp tesislerinde
7. Cam işleme sanayinde
8. Lastik eşya fabrikalarında
9. Endüstriyel boya tesislerinde
10. Mobilya aksesuar sanayinde
11. Montaj sanayinde
12. Hidrofor pompa ve vana sanayinde
13. Entegre et kombinalarında
14. Gıda sanayinde
15. Tekstil sanayinde
16. Kimya sanayinde
17. Tarım sanayinde

### CONVEYOR CHAINS

Conveyor systems is generally used by surface treatment facilities; transportation, shipment and stocking lines; and many other industrial facilities. Following are the main application areas:

1. Powder and liquid paint systems
2. Automotive sub-industry factories
3. White appliance factories
4. Enameled material factories
5. Aluminum material factories
6. Vessel, tank and tube facilities
7. Glass processing industry
8. Rubber material factories
9. Industrial painting facilities
10. Furniture accessories industry
11. Assembly industry
12. Hydrophore, pump and valve industry
13. Integrated meat production facilities
14. Food industry
15. Textile industry
16. Chemical industry
17. Agriculture industry

# TAŞIYICI VE ÖZEL KONVEYÖR ZİNCİRLERİ

## Carrier And Special Conveyor Chains

- Her türlü tarım makineleri, transmisyon ve özel konveyör zincirleri
- Damacana su dolum tesislerinde
- Konserve fabrikaları sanayisinde
- Çimento fabrikaları sanayisinde
- Şeker fabrikaları sanayisinde
- Demir çelik fabrikaları sanayisinde
- Ağaç işleme makineleri sanayisinde
- Makarna ve gıda sanayisinde
- Meşrubat sanayisinde
- Beyaz eşya fabrikaları bant zincirlerinde
- Tekstil fabrikaları sanayisinde
- Zirai aletler zincirleri
- Pim delikli zincirleri
- Makaralı zincirler
- Üniroyal tip zincirler
- Her türlü paslanmaz zincirler
- Paslanmaz kulaklı zincirler
- Paslanmaz polyemit makaralı zincirler
- Özel tip ve ölçülü zincirler
- Muhtelif konveyör zincirleri
- Tüm Makaralı ve Pimli Konveyör Zincirleri, Kulaklı ve Kulaksız Her Türlü Standart Dışı Özel Zincir imalatını Yapmaktayız.
- Any kind of agricultural machineries, transmissions and special conveyor chains
- Carboy water filling facilities
- Canned foods factories
- Cement factories
- Sugar factories
- Iron and steel factories
- Wood processing machines industry
- Pasta and food industry
- Soft drinks Industry
- Band systems of white appliance factories
- Textile factories
- Chains of agricultural machineries
- Chains with pinholes
- Roller chains
- Uniroyal type chains
- Any kind of stainless chains
- Stainless chains with polyamide rollers
- Chains of special types and dimensions
- Miscellaneous conveyor chains
- Our company offers you all conveyor chains with rollers or pins, and any kind of non-standard special chains with or without flanges.



K1



K2



K3



K4



K5



K6



K7



K8



K9



K10



K11



K12



K13



K14



K15



K16



K18



K19

# POWER AND FREE KONVEYÖR RAY VE BARALARI

Power and Free Conveyor Rails and Bara



500 KG - Max. Bara Kapasitesi



1000 KG - Max. Bara Kapasitesi

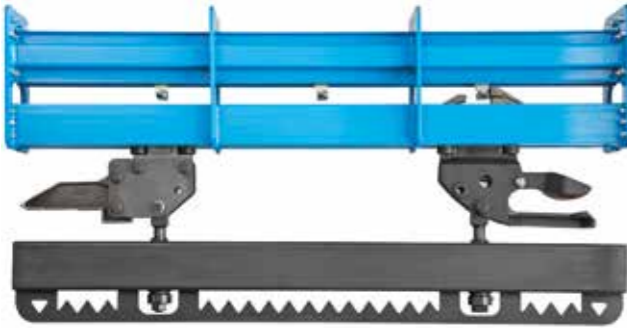

2000 KG - Max. Bara Kapasitesi

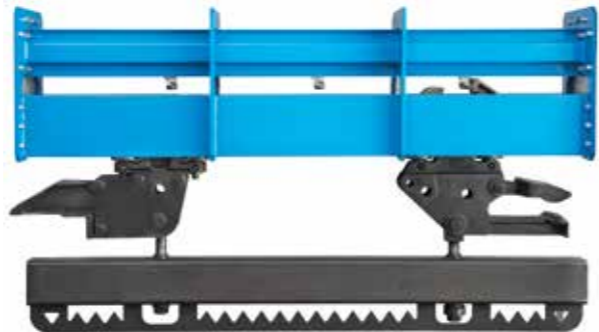

4000 KG - Max. Bara Kapasitesi



# POWER AND FREE KONVEYÖRLER

Power and Free Conveyors



# KARDAN KONVEYÖR RAYLARI VE ZİNCİRLERİ

Cardanic Conveyor Rails and Chains



Vidalı Gergi Rayı  
Screw Tension Rail



Düz Ray  
Flat Rail



İniş - Çıkış Rayı  
Up and Down Rails



45° Yatay Dönüş Rayı  
45° Horizontal turning rail



Yatay Dönüş Rayı  
Horizontal Turning Rail

## KARDAN KONVEYÖR ZİNCİRLERİ - CARDANIC CONVEYOR CHAINS



### HAFİF TİP EM 30/32/35

- Taşıma kapasitesi 35-50 kg'dır.
- Tahrir üstten caterpillar tipi tahrik ünitesi
- 200 mm halve, Avrupa rulmanlı, kardan mafsallı konveyör zinciri
- Kardan tip flans sabitli özel büküm konveyör rayları
- Kardan tip 90 derece 180 derece dönüşlü gergi istasyonları
- Kardan tip 90 derece 180 derece dönüşlü profiller
- Kardan tip iniş çıkış profilleri

### LIGHT TYPE EM 30/32/35

- Load capacity of 35-50 kg
- Top driven with a caterpillar type drive unit
- 200 mm chain pitch, European made roller bearings, conveyor chain with cardanics
- Specially bended conveyor rails with universal joint type fixing flanges
- Universal joint type tensioning stations with 90 and 180 degrees of turn
- Universal joint type profiles with 90 and 180 degrees of turn
- Universal joint type up and down profiles



### ORTA TİP EM 38/40

- Taşıma kapasitesi 70-80 kg'dır.
- Tahrir üstten caterpillar tipi tahrik ünitesi
- 200 mm halve, Avrupa rulmanlı, kardan mafsallı konveyör zinciri
- Kardan tip flans sabitli özel büküm konveyör rayları
- Kardan tip 90 derece 180 derece dönüşlü gergi istasyonları
- Kardan tip 90 derece 180 derece dönüşlü profiller
- Kardan tip iniş çıkış profilleri

### MIDDLE TYPE EM 30/32/35

- Load capacity of 70-80 kg
- Top driven with a caterpillar type drive unit
- 200 mm chain pitch, European made roller bearings, conveyor chain with cardanics
- Specially bended conveyor rails with universal joint type fixing flanges
- Universal joint type tensioning stations with 90 and 180 degrees of turn
- Universal joint type profiles with 90 and 180 degrees of turn
- Universal joint type up and down profiles



### AĞIR TİP EM 45/52

- Taşıma kapasitesi 120-200 kg'dır.
- Tahrir üstten caterpillar tipi tahrik ünitesi
- 200 mm halve, Avrupa rulmanlı, kardan mafsallı konveyör zinciri
- Kardan tip flans sabitli özel büküm konveyör rayları
- Kardan tip 90 derece 180 derece dönüşlü gergi istasyonları
- Kardan tip 90 derece 180 derece dönüşlü profiller
- Kardan tip iniş çıkış profilleri

### HEAVY TYPE EM 45/52

- Load capacity of 120-200 kg
- Top driven with a caterpillar type drive unit
- 200 mm chain pitch, European made roller bearings, conveyor chain with cardanics
- Specially bended conveyor rails with universal joint type fixing flanges
- Universal joint type tensioning stations with 90 and 180 degrees of turn
- Universal joint type profiles with 90 and 180 degrees of turn
- Universal joint type up and down profiles

Standart askılı konveyör sistemlerinde mümkün olmayan;

- Switch ve sensör desteği ile sistemi otomatik durdurma ve çalıştırma
- Taşınan malzemeyi raylarda bulunan makaslar yardımıyla, farklı yönlere aktarma
- Konveyörün değişik bölümlerinde değişik hızlarla taşıma
- Ürün yükleme ve indirme için lift sistemi
- Yüze işlem hatları için tilting sistemi
- Hattin istenilen alanlarında farklı ilerleme hızları

Kontrollerini sistem üzerine entegre olan PLC kontrol sistemi ile kolayca gerçekleştirebilirsiniz. Tasarımlarımız mümkün olduğu sürece üretimimize daha fazla zaman kazandırmak, ekonomik bir sistem kurmak ve en az bakım gerektiren bir sistem anlayışı prensibi ile uzman mühendislik ekibimiz tarafından yapılmaktadır.

You may easily practice the controls, which are not possible with standard suspended conveyor systems, of;

- Stop and actuate the system with the support of switch and sensor,
- Transfer the carried material to different directions through the switches on the rails,
- Carry materials in different speeds at different parts of the conveyor,
- Lift system for product loading and unloading
- Tilting system for surface treatment lines
- Different progress speeds in desired areas of the line

Through the PLC control system integrated on the main system. Our designs are made by our professional engineering staff for saving time for your production as much as possible, establishing an economic system and with the principle of a system requires the least maintenance.

# KARDAN KONVEYÖRLER VE DİĞER EKİPMANLAR

Cardan Conveyors  
And Other Equipment



Askılama Örnekleri  
Hanging Examples

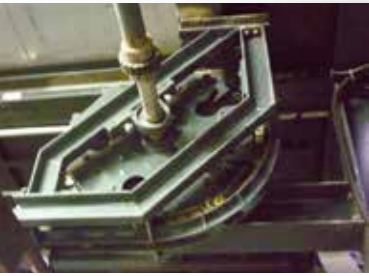

Zincir Dişlisi  
Chain Gear



Konveyör Rulmanları  
Conveyor Bearings



Askı Aparatı Döndürme Ünitesi  
Hanger Rotation Unit



Ray Montaj Aparatı  
Rail Montage Apparatus



Askı Aparatı  
Hanging Apparatus



Model 1



Model 2

Tahrik Ünitesi  
Drive Unit

## Model 3



Tahrik Ünitesi  
Drive Unit



Yağlama Ünitesi  
Lubricating Station



Toz Tavalı Sistem  
Anti-Dust System

# KARDAN KONVEYÖRLER Cardanic Conveyors

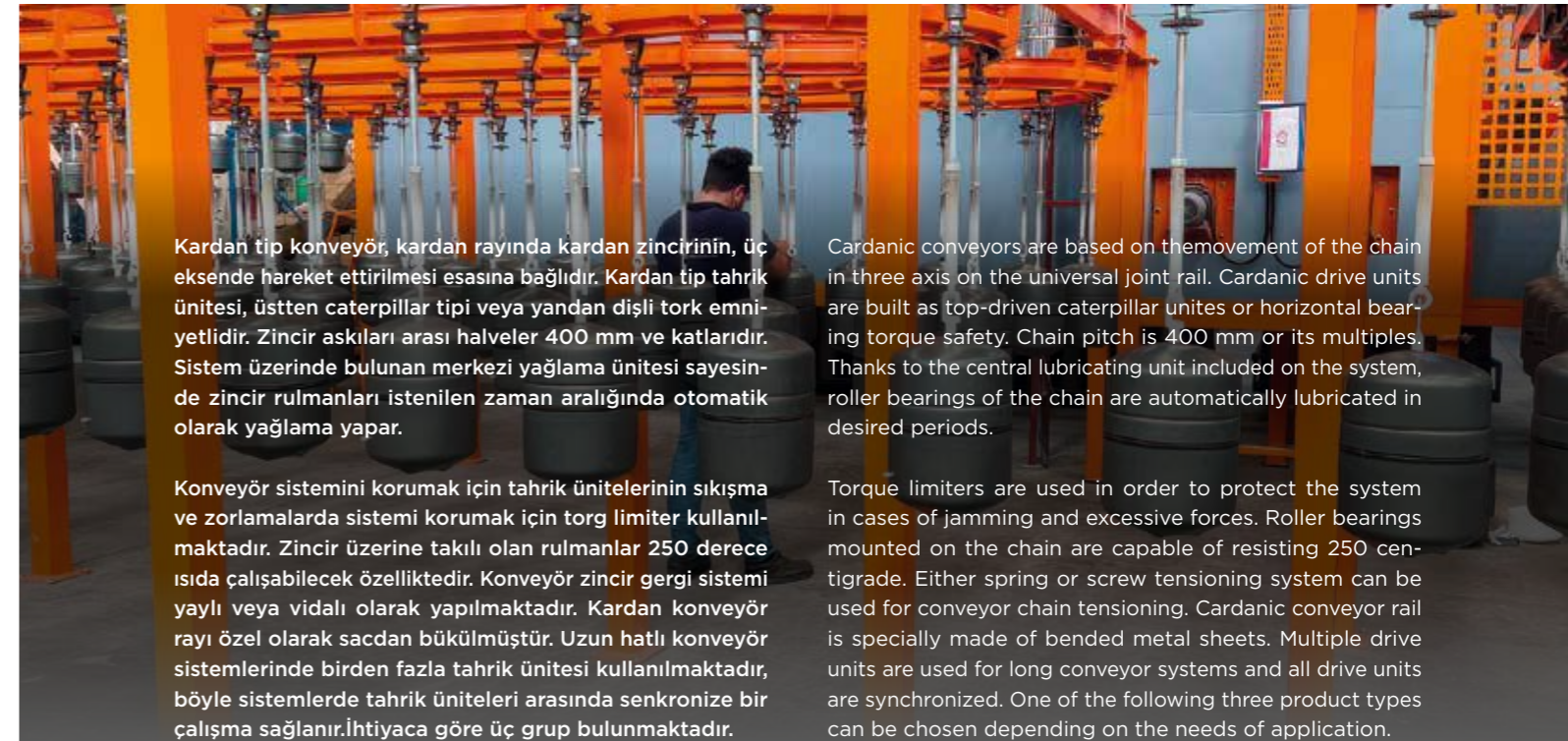

Kardan tip konveyör, kardan rayında kardan zincirinin, üç ekseninde hareket ettirilmesi esasına bağlıdır. Kardan tip tahrik ünitesi, üstten caterpillar tipi veya yandan dişli tork emniyetlidir. Zincir askıları arası halveler 400 mm ve katlarıdır. Sistem üzerinde bulunan merkezi yağlama ünitesi sayesinde zincir rulmanları istenilen zaman aralığında otomatik olarak yağlama yapar.

Konveyör sistemini korumak için tahrik ünitelerinin sıkışma ve zorlamalarda sistemi korumak için torg limiter kullanılmaktadır. Zincir üzerine takılı olan rulmanlar 250 derece ısıda çalışabilecek özelliktedir. Konveyör zincir gergi sistemi yaylı veya vidalı olarak yapılmaktadır. Kardan konveyör rayı özel olarak sacdan bükülmüştür. Uzun hatlı konveyör sistemlerinde birden fazla tahrik ünitesi kullanılmaktadır, böyle sistemlerde tahrik üniteleri arasında senkronize bir çalışma sağlanır. İhtiyaca göre üç grup bulunmaktadır.

Cardanic conveyors are based on the movement of the chain in three axis on the universal joint rail. Cardanic drive units are built as top-driven caterpillar units or horizontal bearing torque safety. Chain pitch is 400 mm or its multiples. Thanks to the central lubricating unit included on the system, roller bearings of the chain are automatically lubricated in desired periods.

Torque limiters are used in order to protect the system in cases of jamming and excessive forces. Roller bearings mounted on the chain are capable of resisting 250 centigrade. Either spring or screw tensioning system can be used for conveyor chain tensioning. Cardanic conveyor rail is specially made of bended metal sheets. Multiple drive units are used for long conveyor systems and all drive units are synchronized. One of the following three product types can be chosen depending on the needs of application.

# FİVET TİPİ KONVEYÖRLER VE DİĞER EKİPMANLAR

Fivet Type Conveyors  
And Other Equipment



Zincir (Y) Askısı  
Chain (Y) Hanging

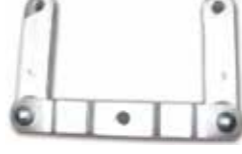

Zincir (U) Askısı  
Chain (U) Hanging



Zincir Döner Askı Çeşitleri  
Chain Roller Hanger Types



Zinciri Merkezi Yağlama Ünitesi  
Central Lubricating Station



Tahrik Ünitesi  
Drive Unit

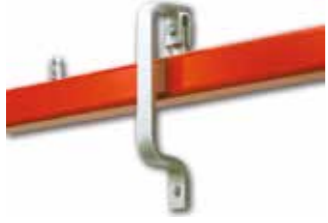

Ters Askılama  
Reverse Hanger

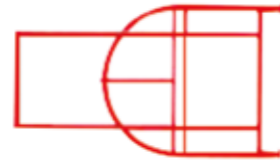

Gergi Ünitesi  
Tensioning Unit

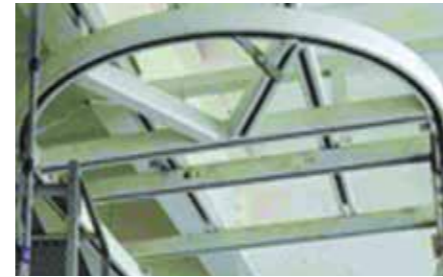

180° Yatay Dönüş Rayı  
Horizontal Turning Rail



Konveyör Düz Ray  
Conveyor Flat Rail



Konveyör İniş - Çıkış Rayı  
Conveyor Up and Down Rails



180° Yatay Dönüş Rayı  
Horizontal Turning Rail



Konveyör Zincirleri  
Conveyor Chains



Konveyör Zincirleri  
Conveyor Chains

# WEBB TİPİ KONVEYÖR ZİNCİR VE TROLLEYLERİ

Webb Type Conveyor Chains and Trolleys

## WEBB TİPİ KONVEYÖR TROLLEYLERİ (ASKI ARABASI)

WEBB TYPE CONVEYOR TROLLEYS (OVERHEAD TROLLEYS)

3" Sifero Döküm "WEBB" Tipi askılı konveyör trolleyi (Makaralı segmanlı tip / Avrupa rulmanlı perçinli) Taşıma kapasitesi 140 kg / 250 derece ısıya dayanıklı

3" Nodular Cast Iron "WEBB" Type overhead conveyor trolley (With support wheels and snap rings / With European made roller bearings and rivets) Load capacity 140 kg / Capable of resisting 250 centigrade

3" Dövme Çelik "WEBB" Tipi askılı konveyör trolleyi (Makaralı segmanlı tip / Avrupa rulmanlı perçinli) Taşıma kapasitesi 140 kg / 250 derece ısıya dayanıklı

3" Nodular Forged Steel "WEBB" Type overhead conveyor trolley (With support wheels and snap rings / With European made roller bearings and rivets) Load capacity 140 kg / Capable of resisting 250 centigrade

4" Sifero Döküm "WEBB" Tipi askılı konveyör trolleyi (Makaralı segmanlı tip / Avrupa rulmanlı perçinli) Taşıma kapasitesi 200 kg / 250 derece ısıya dayanıklı

4" Nodular Forged Steel "WEBB" Type overhead conveyor trolley (With support wheels and snap rings / With European made roller bearings and rivets) Load capacity 200 kg / Capable of resisting 250 centigrade

4" Dövme Çelik "WEBB" Tipi askılı konveyör trolleyi (Makaralı segmanlı tip / Avrupa rulmanlı perçinli) Taşıma kapasitesi 200 kg / 250 derece ısıya dayanıklı

4" Nodular Cast Iron "WEBB" Type overhead conveyor trolley (With support wheels and snap rings / With European made roller bearings and rivets) Load capacity 200 kg / Capable of resisting 250 centigrade

6" Dövme Çelik "WEBB" Tipi askılı konveyör trolleyi (Makaralı segmanlı tip / Avrupa rulmanlı perçinli) Taşıma kapasitesi 550 kg / 250 derece ısıya dayanıklı

6" Nodular Cast Iron "WEBB" Type overhead conveyor trolley (With support wheels and snap rings / With European made roller bearings and rivets) Load capacity 550 kg / Capable of resisting 250 centigrade

## WEBB TİPİ KONVEYÖR ZİNCİRLERİ - WEBB TYPE CONVEYOR CHAINS CHAINS



3" Dövme Çelik "WEBB Tipi" askılı konveyör zinciri (zincir hatvesi 76,2 mm)

3" Forged Steel "WEBB Type" overhead conveyor chain (chain pitch 76.2 mm)



4" Dövme Çelik "WEBB Tipi" askılı konveyör zinciri (zincir hatvesi 102,4 mm)

4" Forged Steel "WEBB Type" overhead conveyor chain (chain pitch 102.4 mm)

6" Dövme Çelik "WEBB Tipi" askılı konveyör zinciri (zincir hatvesi 153,2 mm)

6" Forged Steel "WEBB Type" overhead conveyor chain (chain pitch 153.2 mm)

## WEBB TYPE



# WEBB TİPİ KONVEYÖRLER VE DİĞER EKİPMANLAR

Webb Type Conveyors  
And Other Equipment



Askılama Örnekleri  
Hanging Examples



Shopleyt



Dönüş Ruloları ve Pimleri  
Turning Rolls and Pins



Zincir Döner Askı Çeşitleri  
Chain Roller Hanger Types



90° Kasnaklı Tip Yatay Dönüş  
90° Horizontal Turning  
Apparatus with pulley



90° Rulolu Tip Yatay Dönüş  
90° Horizontal Turning with Roll



Caterpillar Tahrık Zinciri ve Tırnakları  
Caterpillar Drive Chain and Teeth



180° Kasnaklı Tip Yatay Dönüş  
180° Horizontal Turning  
Apparatus with Pulley



Zincir Gergi Ünitesi  
Tensioning Unit of Chain



180° Rulolu Tip Yatay Dönüş  
180° Horizontal Turning with Roll



180° Dönüşlü Tahrık Ünitesi  
Drive Unit with 180° Turn



Caterpillar Tahrık Ünitesi  
Caterpillar Drive Unit

# WEBB TİPİ KONVEYÖRLER

## Webb Type Conveyors

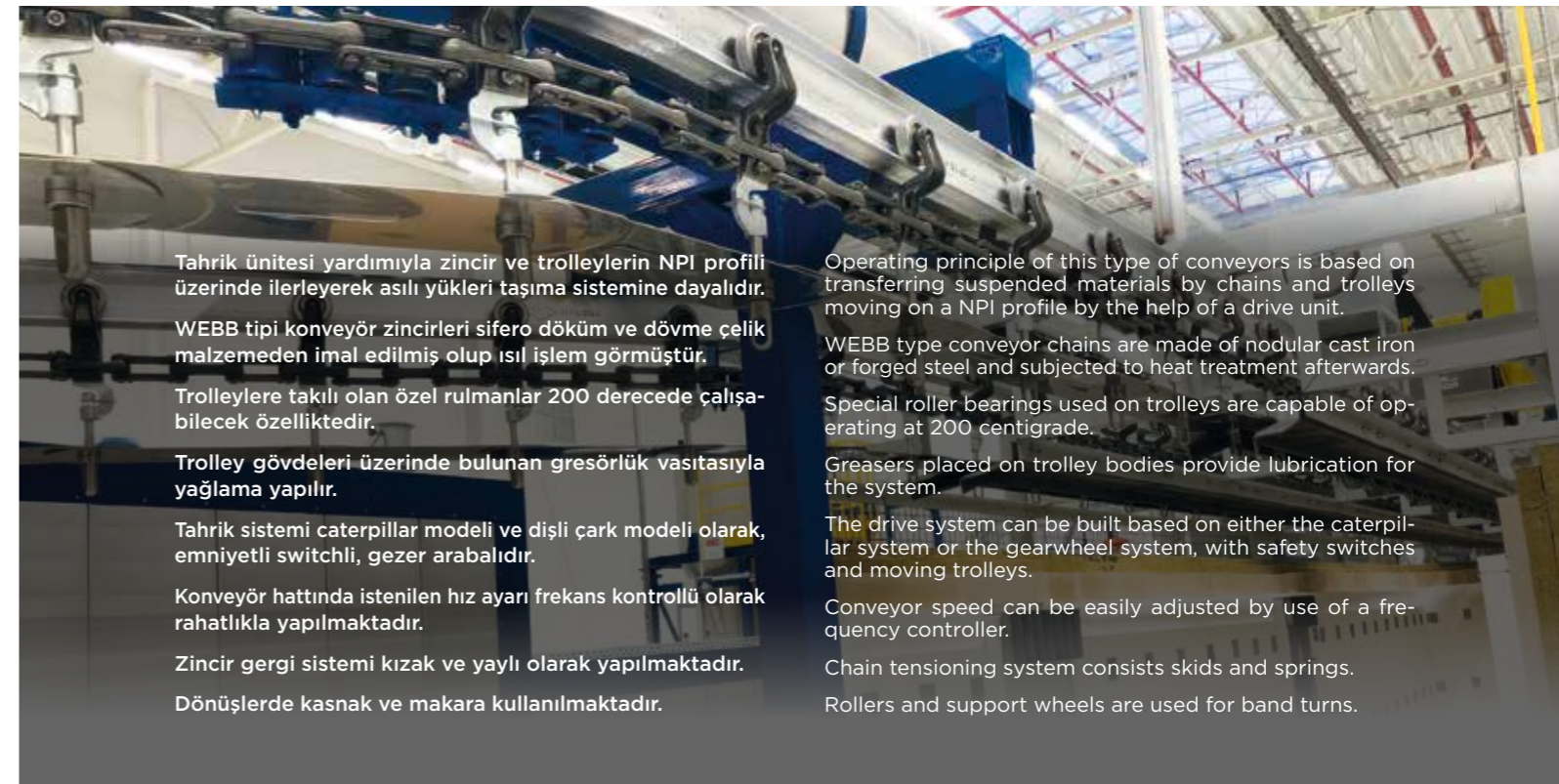

Tahrık ünitesi yardımıyla zincir ve trolleylerin NPI profili üzerinde ilerleyerek asılı yükleri taşıma sistemine dayalıdır.

WEBB tipi konveyör zincirleri sifero döküm ve dövme çelik malzemeden imal edilmiş olup ısı işlem görmüştür.

Trolleylere takılı olan özel rulmanlar 200 derecede çalışabilecek özelliktedir.

Trolley gövdeleri üzerinde bulunan gresörlük vasıtasıyla yağlama yapılır.

Tahrık sistemi caterpillar modeli ve dişli çark modeli olarak, emniyetli switchli, gezer arabalıdır.

Konveyör hattında istenilen hız ayarı frekans kontrollü olarak rahatlıkla yapılmaktadır.

Zincir gergi sistemi kızak ve yaylı olarak yapılmaktadır.

Dönüşlerde kasnak ve makara kullanılmaktadır.

Operating principle of this type of conveyors is based on transferring suspended materials by chains and trolleys moving on a NPI profile by the help of a drive unit.

WEBB type conveyor chains are made of nodular cast iron or forged steel and subjected to heat treatment afterwards.

Special roller bearings used on trolleys are capable of operating at 200 centigrade.

Greasers placed on trolley bodies provide lubrication for the system.

The drive system can be built based on either the caterpillar system or the gearwheel system, with safety switches and moving trolleys.

Conveyor speed can be easily adjusted by use of a frequency controller.

Chain tensioning system consists skids and springs.

Rollers and support wheels are used for band turns.

## KONVEYÖR PROJELERİ

Conveyor Projects



## RULOLU VE TAŞIYICI MANİPÜLATÖR

Roller and Carrier Manipulator



## KAYAR ARABALI KONVEYÖR

Sliding Trolley Conveyor



## HİDROLİK MAKASLI LİFT

Hydraulic Trussed Lift



Konveyör sistemlerimize yardımcı ekipman olarak ürettiğimiz bu ürün, konveyörlerimizde taşınacak ağır yüklerinizi yer seviyesinden konveyöre taşınma ihtiyaçlarınızda kullanmanız için tasarlanmıştır.

İstenilen ebatlarda ve kapasitelerde imal edilebilmektedir.

This product we produced as the auxiliary equipment for our conveyor systems was designed for being used in lifting the heavy materials, to be carried in our conveyors, from ground level to the conveyor.

The product can be manufactured in the requested dimensions and capacities.

## ÇELİK PALETLİ KONVEYÖRLER

Steel Palletized Conveyors



Çelik paletli konveyör sistemleri, bir çok endüstriyel taşıma sisteminde çok geniş bir uygulama alanı için idealdir. Bant yükü, taşıma uygulamalarında kullanımı yanında gevşek parçaları iletmek için ideal koruma rayları ile inşa edilir.

İsteğinize bağlı olarak çeşitli bant konveyör tasarımları ve performans konfigürasyonları ile üretim sürecimizi gerçekleştirmekteyiz. Müşteri isteğine ve kullanım amacına göre sistemlerimiz değişmektedir.

The steel palletized conveyor systems offer solutions for a wide range of application areas in many industrial carrying systems. The band is constructed with the ideal protection rails for carrying the non-rigid parts, besides its use in carriage practices.

We ensure our production process through optional band conveyor designs and performance configurations. Our systems vary in accordance with the customer demands and the intended use.

## BANT KONVEYÖRLERİ

Belt Conveyors



## SKID KONVEYÖR

Skid Conveyor



## TAHİL VE SİLO KONVEYÖRLERİ

Grain and Silo Conveyors



## TALAŞ VE ÇAPAK KONVEYÖRLER

Chip Conveyors



## ÖZEL KONVEYÖR ZİNCİRLERİ

Special Conveyor Chains

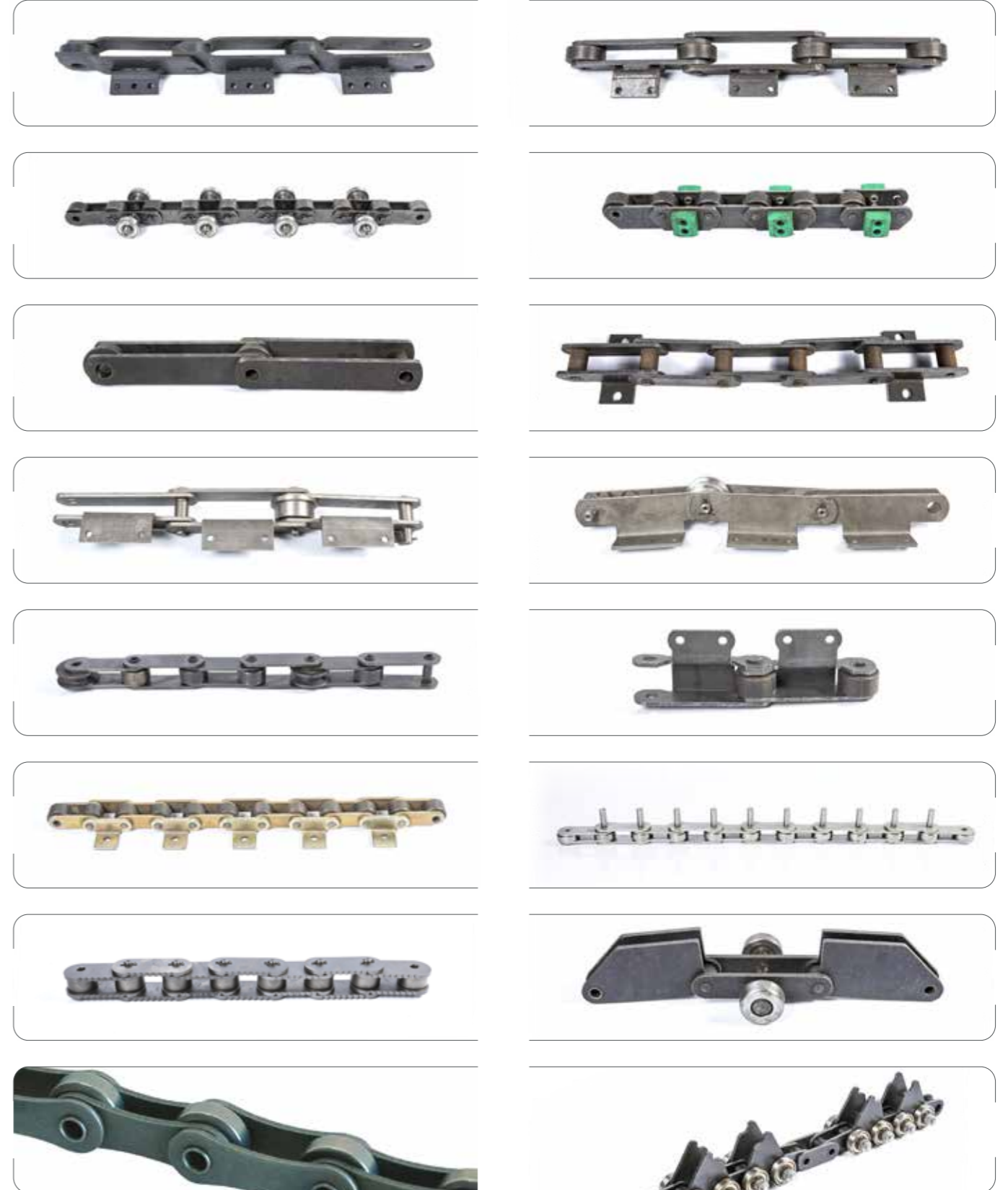

# ÖZEL KONVEYÖR ZİNCİRLERİ

Special Conveyor Chains



# REFERANSLARIMIZ

Our References



# REFERANSLARIMIZ

## Our References



# REFERANSLARIMIZ

## Our References

